

How to use

PC-logger 3150 Hardware with accessories

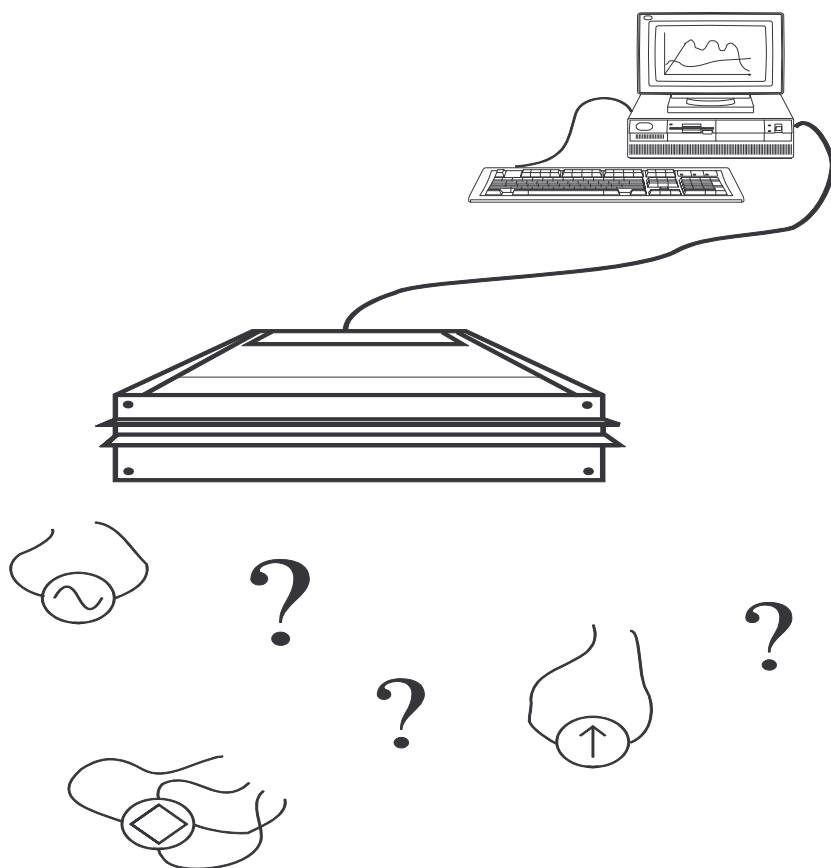

Interface-Teknik AB
Gjutarevägen 1
SE-443 61 STENKULLEN
Tel. +46(0)302-246 00
www.intab.se, info@intab.se

MANUALS of the PC-Logger 3150 System:

-"How to Use PC-Logger 3150 "

How to connect sensors and transducers correctly

-"EasyView - manual"

A tutorial guide to a user-friendly expert data analysis program

-"Command Manual"

Describes the ASCII strings (used by software) that make the PC-Logger 3150 tick

6.7	POWER	29
6.8	MECHANICAL SPECIFICATIONS	29
	OPTION: Digital I/O and Pulse Counters.....	31
1	OVERVIEW	31
1.1	DIGITAL OUTPUTS.....	31
1.2	DIGITAL INPUTS	32
1.2.1	<i>Opto isolated inputs.....</i>	32
1.2.2	<i>TTL-compatible inputs.....</i>	32
2	COUNTERS	33
2.1	RESET MODE	33
2.2	NORMAL MODE	33
3	CONNECTIONS.....	34
3.1	DIGITAL OUTPUTS	35
3.2	DIGITAL INPUTS	35
3.2.1	<i>Opto Isolated.....</i>	36
3.2.2	<i>TTL Compatible.....</i>	36
4	TECHNICAL DATA	37
4.1	DIGITAL OUTPUTS.....	37
4.2	DIGITAL INPUTS (@ 25C +/-10C)	37
4.2.1	<i>Opto Isolated Inputs.....</i>	37
4.2.2	<i>TTL-compatible inputs.....</i>	37
4.3	AUXILIARY POWER	38
4.3.1	<i>for Opto-Couplers</i>	38
4.3.2	<i>for TTL-Inputs.....</i>	38
	INDEX.....	39

MAIN UNIT

1 AN OVERVIEW

1.1 General Information

The PC-Logger 3150 is a very versatile addition to our line of Analog to ASCII Converters. It will cover the medium measuring rate range: up to a 1000 times per second.

Input ranges are +/-10V; +/-1000mV; +/-100mV; +/-50mV; 20mA.

Pulse counters are available as an optional add-on.

An PC-Logger 3150 together with software and a personal computer constitutes a powerful data acquisition system.

The main use is off-line when an internal memory (optional) of the PC-Logger 3150 stores data for later transferral to computer.

On-line use is also possible but is limited by the performance of connected computer. Max speed has to be determined by experiment.

Main features are :

- **8 analog inputs**
- **Programmable ranges on all inputs**
- **12 bit ADC**
- **Off-line memory data storage (optional)**
- **Trigger input and output**
- **Auxiliary voltage output**
- **Programmable sampling interval: 1ms to 1000ms**
- **Fully compatible with all INTAB logger software**

The scope of this manual is to enable the user to correctly connect sensors and transducers and use the PC-Logger 3150 off-line.

How the PC-Logger 3150 is handled using our software and a PC is explained in the program manual and by the program itself by its user-friendly and self-explanatory menus.

<p>For best use and best results it is ABSOLUTELY essential that this manual is studied in its entirety. Special emphasis should be put on studying chapter 3 which describes how to connect transducers and other signal sources.</p>

1.2 On-line Recordings

On-line measurements are performed with the PC-Logger 3150 connected to the computer's RS-232 port. Measurements can in this mode be monitored in real-time on the computer's display. The user must however be aware of the speed-limitations set by the computer: don't expect it to handle more than eight channels five times a second. If you are the fortunate owner of a faster computer with a fast disk-drive you can probably go faster. The user him/herself has to determine the maximum speed on his/her particular computer.

1.3 Off-line Recordings

Off-line recordings are possible with loggers equipped with (optional) data memory.

Off-line measurements should be preceded by the transferral of measurement parameters from the computer to the PC-Logger 3150.

These parameters contain, among others (see program manual), information about measurement interval and what channels that are to be active. They are effective until a new set of parameters are downloaded. The PC-Logger 3150 can, after downloading of the parameters, be disconnected from the computer and started with the help of the keys next to the LCD (see section 1.5). After all measurements are completed (see stop : section 4.2) the PC-Logger 3150 is again connected to a computer for transferral of collected data (X-fer).

1.4 Storage Capacity

The number of measurements that can be stored by the PC-Logger 3150 and/or computer is dependent on the size and type of memory used.

The longest possible duration of a recording is a function of the number of channels that are active, sampling rate and the size of the storage medium.

A discussion of how the maximum length of a recording can be calculated from known parameters follows below.

It is assumed that recordings are made using software supplied by INTAB.

1.4.1 Storage capacity in Computer

Storage capacity in your computer can readily be calculated. The amount of free space on the disk that will store your measurement data is the limiting factor.

A 3½" disk will store more than 1,400,000 bytes. This is sufficient to store a total of 700 000 values.

If we now consider a case where you sample and store 5 channels per second the following formula applies:

Measuring time = $700\ 000/5 = 140\ 000$ seconds or almost 40 hours. This time is naturally multiplied by five if you only use one channel.

Another example: this storage space can be two measurement rounds, each of two channels every other millisecond for a total duration of 700 seconds (or nearly twelve minutes).

The formula you use is: interval*storage capacity divided by 2 and the number of active channels : $I*S/(2*C)$.

Apply this to a hard disk, and you will find that storage space will last a very long time.

Remember that total storage time in a disk is the sum of all recordings. You just have to allow for a header space of 16k bytes.

1.4.2 Storage Capacity in the PC-Logger 3150

Storage capacity in the PC-Logger 3150 itself is calculated almost in the same way as it is calculated in the on-line case.

Three sizes of memory can be supplied: 64k, 64k+512k or 64k+1M. Every value stored uses two bytes, so the formula in the previous section can be used here too.

An example: having 64k memory, you want to measure four channels 10 times every second. The interval is 0.1 seconds.

The formula will then be: $0.1*64,000/(2*4)=800$ seconds.

Note:

The internal memory of the PC-Logger 3150 will only store one recording at a time. Starting a new recording will erase the previous one.

Recordings have to be transferred to your computer before loading new parameters or starting new measurements.

There is no limit to the number of times the same recording can be transferred to the computer.

Measurement data will also not be lost if the internal batteries run down. A back-up lithium battery will retain data for more than 10 years.

1.5 Block Diagram

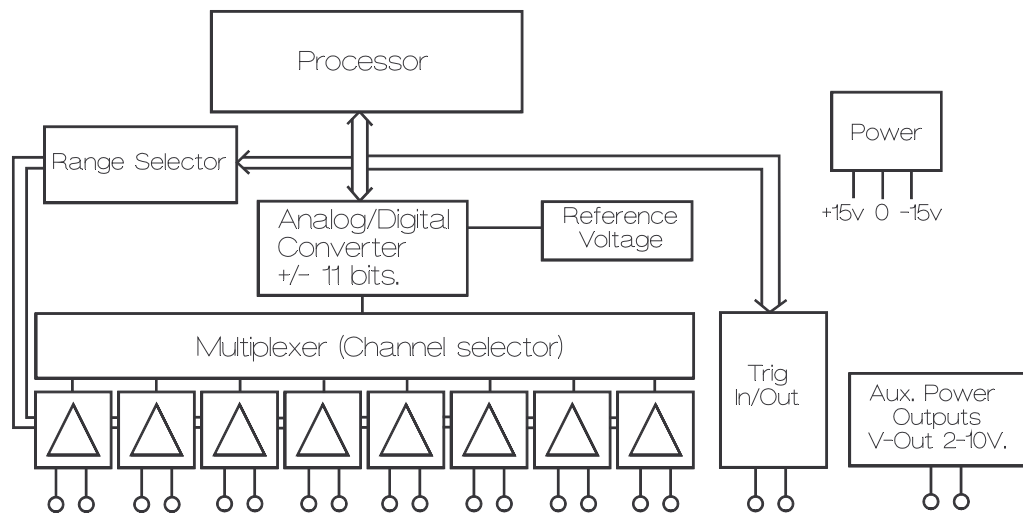

This illustration shows a simplified block diagram of the PC-Logger 3150. The expert notes that all amplification takes place **before** the multiplexer.

1.6 Display and Keys (option)

The LCD (Liquid Crystal Display) with adjacent keys are supplied with all PC-Logger 3150:s that are equipped with internal measurement data memory. This display and key combination is indispensable when making off-line recordings.

You indicate which function you want using the up/down arrows and then confirm your choice with the **OK**-key.

The **Multimeter** is used to check transducer connections and function before recording is started. You scroll up and down among the channels using the up/down keys. Automatic scrolling is started with the key "hidden" under the logo. A new channel is then shown every three seconds (try this feature by pressing "PC-Logger 3100").

Record is selected when you intend to collect data. Verify your choice with "OK". See illustration below and section 4 of this manual.

Starting a new recording will delete the previous one.

Don't forget to transfer data to the computer between recordings.

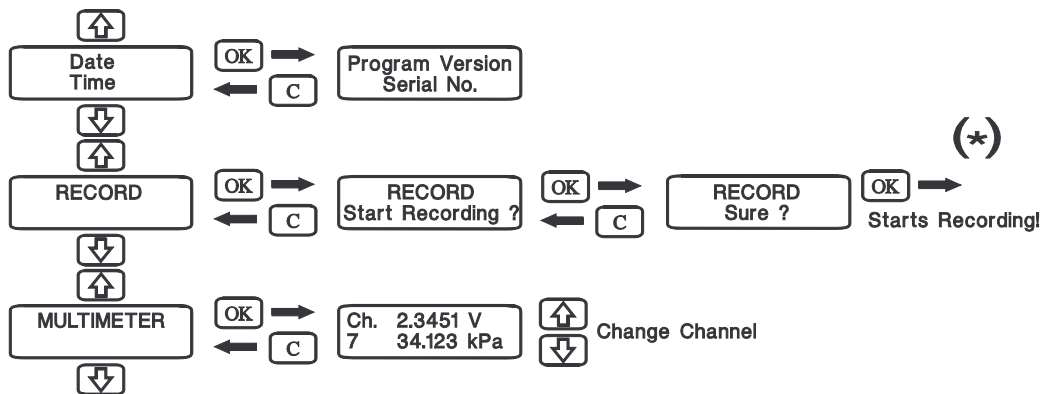

(*) See section 4 : TRIGGER.... for further information on starting and stopping a recordings

1.6 Power supply

The PC-Logger 3150 is normally powered by the supplied mains adaptor. It has an output of 13.5V at a max of 500mA.

The PC-Logger 3150 is also fitted with internal rechargeable batteries. They will give the user at least one hour of recording time without mains supply. The batteries are trickle charged when the mains adaptor is connected. There is no danger of overcharging the batteries, they **should** be left on charge to prolong their life and keep them ready to use at all times.

Some applications require the PC-Logger 3150 to be powered by other sources.

Use a cable fitted with a TA3F (Switchcraft) connector to connect to, for example, a car battery.

Don't use sources supplying more than 16V as this is the maximum allowed.

The PC-Logger 3150 will "fall asleep", if it isn't powered by an outside source, about two minutes after the last command or key-stroke has been entered. This feature saves your rechargeable batteries for when they are needed.

Incoming serial (RS-232) commands or pressing the C-key will wake the PC-Logger 3150.

2 INPUTS/RANGES

NOTE !

To get good results it is of utmost importance that all signals to be measured are connected correctly.

Experience tells us that 95% of all problems (like noise, electrical interference, measurement errors etc.) are the result of incorrect connections and wiring.

A careful study of sections 2 and 3 is therefore highly recommended.

All analog inputs are **differential** and have no internal connection to signal ground. The impedance between the positive and negative inputs to ground is of the order of several megohms. They must therefore never be allowed to float outside the specified common mode range, but must be referenced to ground in some way.

The inputs are also balanced making them very unsusceptible to electrical noise. Sensor wiring can be very long if a pair of twisted wires is used and the ground reference is connected to the lowest potential of the signal source via a separate wire.

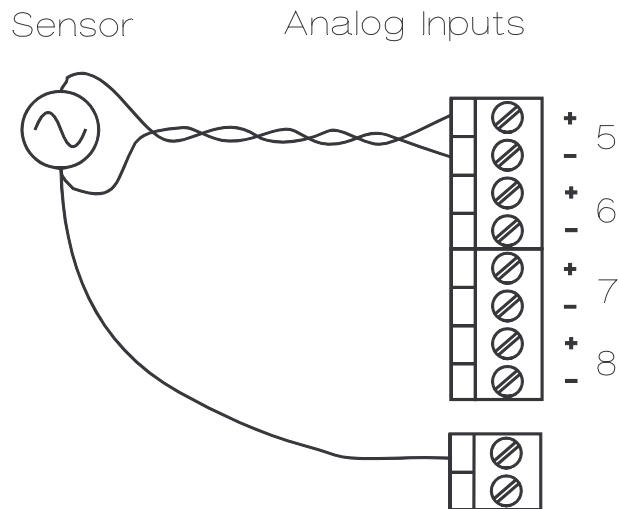

2.1 Ranges: Voltage and Current

Each programmable (option) range or preset range has a resolution of at least +/-1800 divisions.

Translated into measured units this can be illustrated like this:

RANGE	RESOLUTION	ACCURACY
+/-10V	5.5mV	0.12% of FSR
+/-1000mV	0.55mV	0.12% of FSR
+/-100mV	0.055mV	0.12% of FSR
+/-50mV	30 μ V	0.12% of FSR
+/-20mA	11 μ A	0.12% of FSR

Each channel has an internal 51 Ω shunt that is used to measure current. It is connected into the input circuitry by putting the small DIP-switch in position "current".

3 CONNECTIONS

3.1 Power

Power is applied through a TA3F (Switchcraft) female connector connected as follows :

- Pin 1 : 13 - 16VDC
- Pin 2 : 0V
- Pin 3 : 18 - 24VDC

N.B. Connecting power through pin 3 is an alternative to pin 1 !

3.2 Computer

PC-Logger 3150 connects to a serial port of the computer using the supplied spiral cable.

The 15 pin D-Sub connector has the following pinouts:

- pin 2: Tx
- pin 3: Rx
- pin 5: CTS
- pin 6: DTR
- pin 7: GND

Leave the rest of the pins unconnected!

Typical PC-Logger 3150 to computer cables:

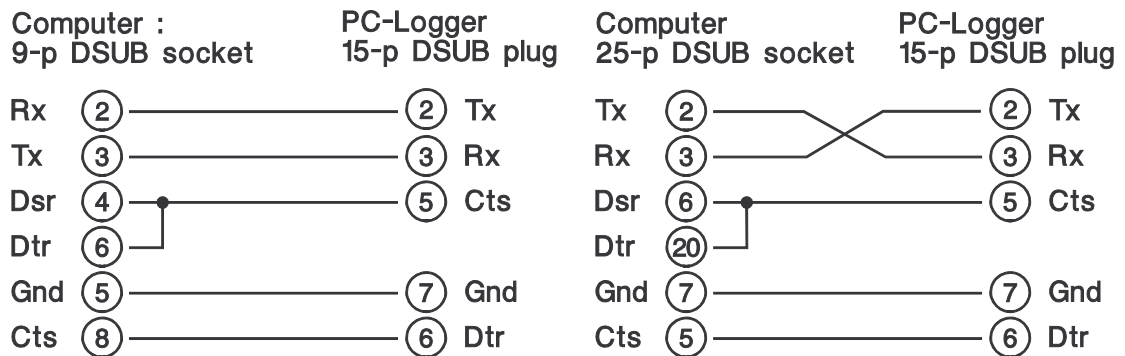

3.3 Inputs

Transducers and sensors connect to the detachable screw terminals. Here is an illustration of how the screw terminals are placed.

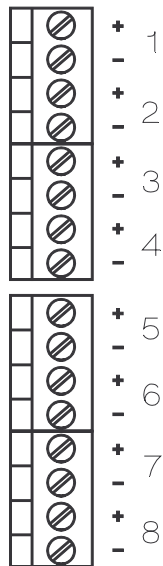

These are analog channel inputs.

Behind each channel input terminal there is a pair of Dip-switches.

One (Volt/Current) connects the shunt resistor into the input circuitry for current measurements (0 - 20mA).

The other (Diff/ Gnd) shorts the negative input to signal (or reference) ground for single ended measurements.



Gnd

This terminal (**Gnd**) is logger signal ground. All signals **must** in some way be referenced to this point.

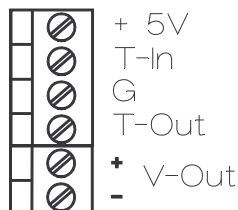

+ 5V

T-In

G

T-Out

+ V-Out

"**+5V**" is an auxiliary voltage for the Trig input (T-in).

"**T-in**" is a trigger input to start or stop recordings.

"**G**" is the signal return (ground) for trig-signals.

"**T-out**" is an output reflecting trig status.

"**V-Out**" is an auxiliary voltage for sensors or x-ducers. Its voltage is adjustable between 2V and 10V by a potentiometer.

These terminals are found under the lid of the logger. They are detachable. Use the 16-hole bracket as strain-relief for transducer cables. You can use a tie-wrap or simply thread the wire through two holes.

NOTE!

These terminals are accessible also in those loggers that are equipped with an optional jack panel. The **jack panel** must be regarded as just an extension box and **does NOT make familiarisation with the terminal area unnecessary**. The user still has to determine how the dip-switches are to be programmed.

3.3.1 Differential Inputs

There are two basic requisites that have to be fulfilled when connecting signals and/or sensors and transducers :

- 1 - No signal must be left floating with respect to logger signal ground.
- 2 - System grounds must be connected so that no ground loops are created.

Use a one-point grounding scheme!

The following sections will help in understanding how this can be achieved.

Let us first take a look at a block diagram of the inputs.

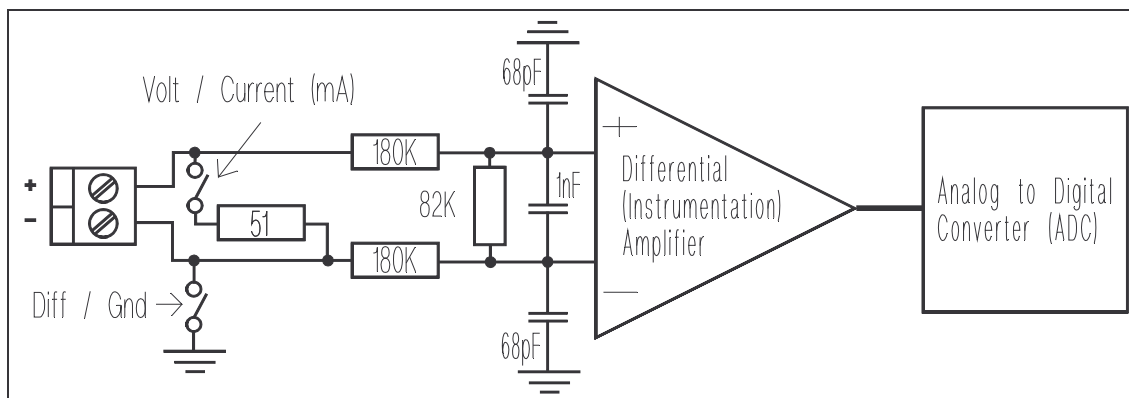

Differential channels (inputs) can be considered to be **two** different inputs:

- the - input measures the voltage between the GND and -
- the + input measures the voltage between the GND and +

The **difference** between these two voltages is then "calculated" internally.

From the above it must be obvious that just applying a voltage between - and + **cannot possibly work!** The amplifier must see signals referenced to GND. (GND, by the way, is an internal "signal ground" or reference that has **nothing** in common with mains protective ground or any other ground that may be lying around.)

If you have problems in understanding this, it is a good idea to tie the - input to GND by putting the "Diff/Gnd" switch in position "Gnd". The result will be that the channel will measure the voltage at the + input and then subtract the voltage at the - input (which is zero volts) and present the correct value.

Just be sure that all your minuses have the same potential so that no smoke signals are generated.

N.B.

In all work connecting signals to the logger you have to take the following points into account :

- **Analog ground is common to all channels.**
- **Analog ground is internally connected to RS-232 signal return (D-sub pin 7).**
- **Analog ground is internally connected to power input return (pin 2).**
- **Analog ground is internally connected to trig input and output signal return ("G")**
- **Analog ground is internally connected to negative V-out.**

3.3.2 Common Mode

To maintain accuracy in your measurements you have to take the common mode range into account. The common mode range is 10V. This is another way of looking at or taking advantage of the "differentiality" of the inputs.

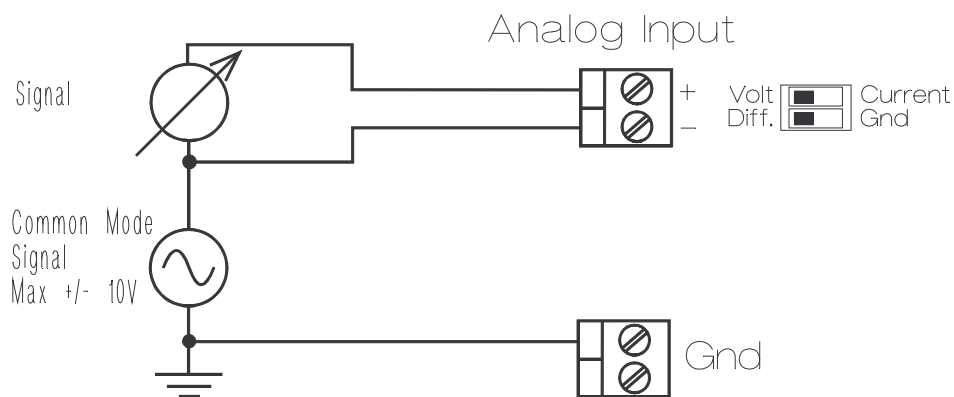

The impedances between "Gnd" and positive and "Gnd" and negative inputs are very high. This means that unless they in some way are connected, the inputs may float electrically, way beyond the allowed limit. The inputs will not be damaged by voltages above this as long as they are within 30V off signal ground.

The following sections of this manual will provide some examples of how transducers can be connected.

3.4 Sensor Connection Examples

Transducers can supply signals of differing types. They are usually "single ended" or "differential" (ratiometric). Below are some examples of how they can be connected. Note that combinations are always possible.

It is also always good practise to plan connections and to make a schematic diagram before actually doing them.

3.4.1 Connecting 20mA current loops

Currents are usually process type signals: 0-20mA or 4-20mA.

These loops can be connected in more ways than one.

It cannot be stressed enough that it is necessary to have a diagram of the system from which these signals emanate in order to connect multiple signals correctly.

Remember that the 51Ω shunt resistor has to be connected to the input circuitry by putting the Dip-switch in position "current". See illustrations below.

1) Connecting current loops with common grounding :

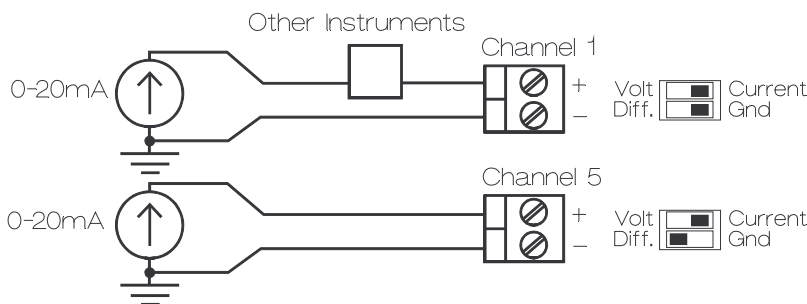

One connection to the common ground potential is enough.

Two would have created a ground loop that may cause problems in the form of electrical interference.

"Other instruments" may also be connected in the current return path if it is absolutely certain that the total voltage drop across them is well within max common mode range.

2) Connecting floating (ungrounded) current loops

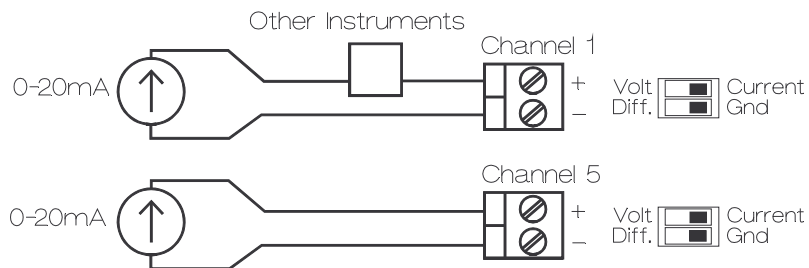

All signals have to be referenced to "Gnd". They may otherwise drift outside the common mode range.

3) Connecting two-wire mA transmitters using power from V-out.

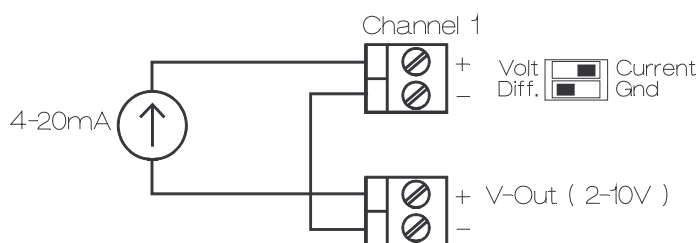

The auxiliary Voltage output (V-out) can power 20mA transmitters. Make sure that the voltage is sufficient for your x-mitter.

4) Connecting two-wire mA transmitters powered by external source.



Transmitters that require higher voltages have to be powered by an external source. Don't forget to put the dip-switch in position "Gnd" unless this source has some other connection to logger ground.

3.4.2 Connecting Voltage Signals

Voltage signals can be connected in two basic ways. Which one to use depends on whether the signal is "floating" or not.

Combinations of the two methods are of course possible!

Differential or ratiometric transducers may also be directly connected.

1) Connecting signals with common grounding

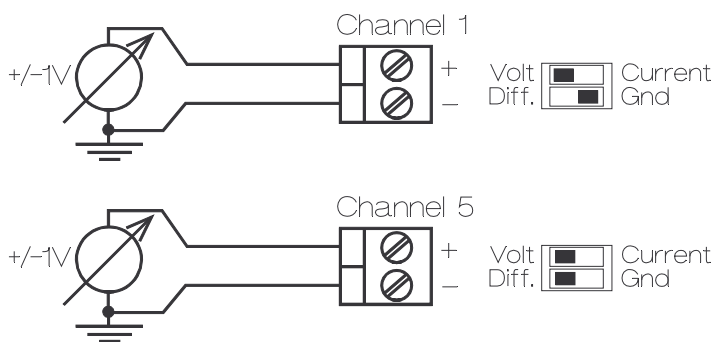

Note that only one of the Diff/Gnd switches is in position "Gnd". This will establish a good reference potential for both channels.

2) Connecting isolated or "floating" signals.

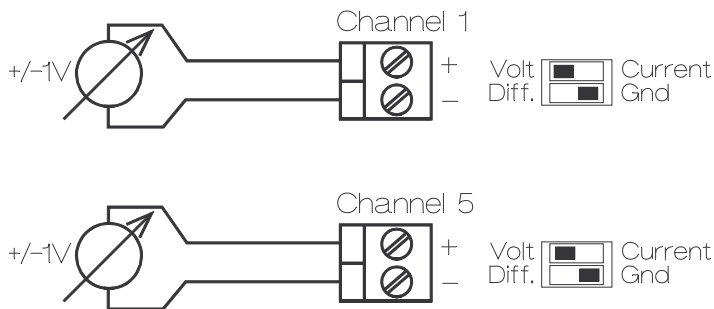

Each floating signal has to be individually grounded to logger "Gnd".

3) Differential or Ratiometric transducers

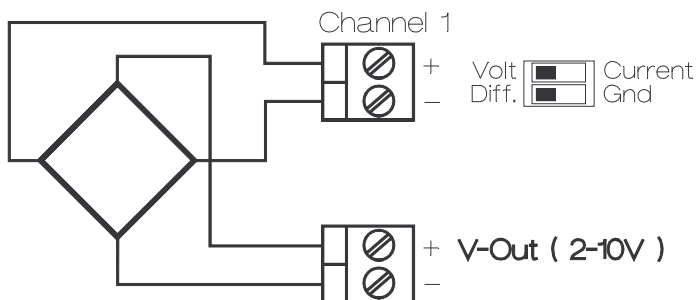

This illustration shows how a bridge type transducer (load cells, pressure sensors etc.) should be connected. The "V-out" is used as excitation voltage.

3.5 Common connection errors

1) Ground loops:

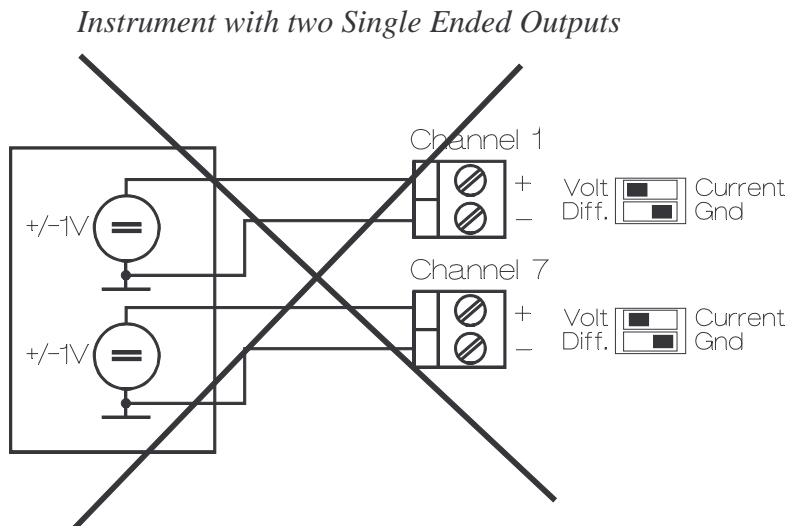

Two apparently separate outputs from an instrument are each connected to a channel. Both channels have the negative input shorted to ground via the "Diff/Gnd"-switches.

Measured values may be either unstable or inaccurate.

Solution: break the ground loop by putting one of the switches in the "Diff" position.

2) Floating signal : no connection to system ground

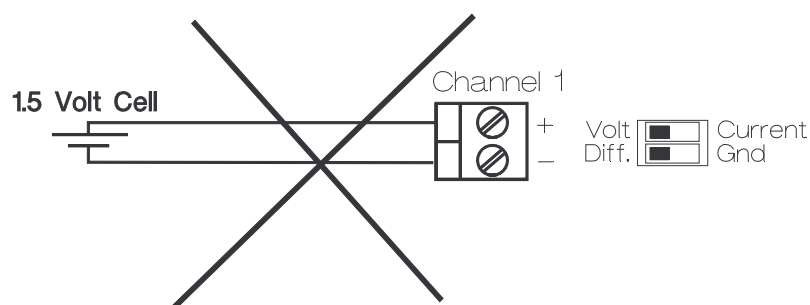

A signal equivalent to a common flashlight battery is connected to + and - of one of the channels. Readings are unstable.

Solution: give this signal a proper ground reference by shorting the negative input to logger ground by placing the Dip-switch in the "Gnd" position.

3) Common mode voltage too high.

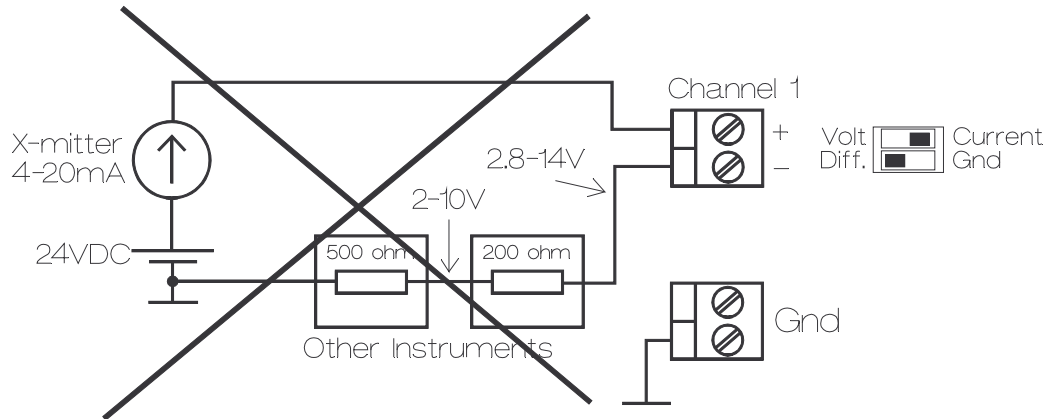

In many industrial applications, the signal from one mA transmitter may be monitored by several instruments. These are always connected in series. If the total series resistance of these instruments causes a voltage drop of more than 10V AND if it appears on the ground side of the logger, the common mode range is exceeded. This will cause the input amplifier to saturate resulting in inaccurate readings.

Solution 1 : move other instruments to positive side of channel.

Solution 2 : use isolation amplifiers.

4) Absurd value when measuring in current loop (defect x-mitter?)

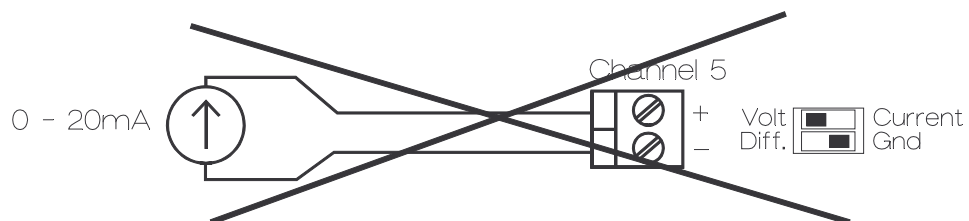

The logger shows an absurdly high value and the x-mitter seems to be defect. This will be the result if the "Volt/Current" switch has been left in the Volt position.

The x-mitter will try to output its current through the high impedance of a voltage input instead of the 50Ω of the current shunt. It will consequently output as much Voltage as it can, again making the input amplifiers saturate.
Solution : put the Dip-switch in the "Current" position.

5) Bridge connection error

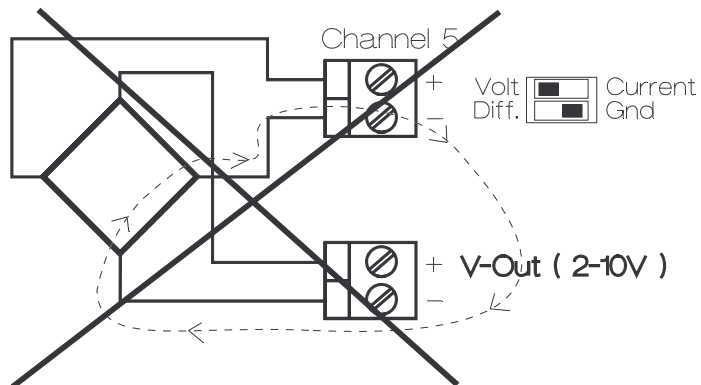

The illustration shows how one leg of a bridge type transducer (f. ex. load cell or pressure transducer) may be shorted by mistake.

The V-out negative terminal is internally connected to logger ground. By connecting the negative input by placing the switch in the "Gnd" position one of the resistors in the bridge is effectively shorted.

Solution : place the switch in the "Diff" position.

4 STARTING RECORDINGS

As you have seen in the previous sections, there are two ways of recording data: on-line and off-line.

Programs supplied with the PC-Logger 3150, guide the user through the set-up procedures necessary before recordings can be started.

On-Line Recordings are initiated from the computer.

Data is then continuously transferred via the RS-232 interface and stored on disk.

The user must however be aware of the limited speed at which data can be acquired in this mode (see 1.1).

This mode is explained in detail in the software manual. The rest of this section will therefore deal exclusively with off-line recordings.

Off-line recordings are prepared by setting the appropriate parameters with the help of the supplied software (see program manual).

Start and Stop parameters are particular to the "f"-version of the PC-Logger 3150. How they work is explained below.

Start and Stop levels are programmed in the "Activate channels" part of the program. Access to this facility is gained in the "TRIG" column.

Don't forget to switch these levels **ON** after you have programmed them.

Start and Stop parameters are activated in the "parameter" part of the software.

4.1 Start Trig

There are four different factors that may start the PC-Logger 3150 recording after "Start Recording" has been okayed by the operator:

- 1 - Another "OK" key-stroke or
- 2 - A logical high at the trig input or
- 3 - An analog signal outside a programmed level or
- 4 - A logical high at the trig input followed by an analog signal outside a programmed level

4.1.1 Start on key-stroke

Use the keys next to the LCD and "OK" all steps up to the point where it says RECORDING: READY FOR STOP.

It will now record with set sampling interval until a stop condition is met.

4.1.2 Start on digital input

A digital signal may be connected to the trig input. A high level will start the recording if the LCD shows "STANDBY ... READY TO START".

A "high level" is a voltage above 4V.

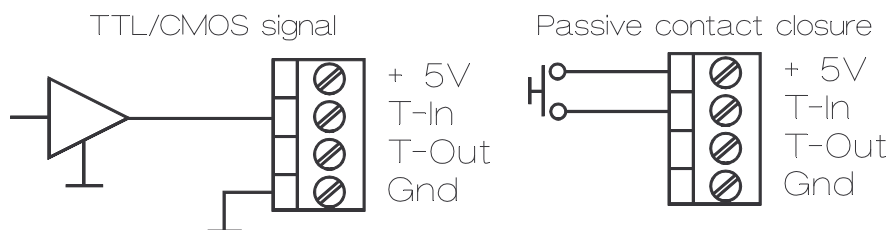

The digital input source may be either a TTL/CMOS signal or a simple contact closure. Be sure to get your wiring correct and note that the GND is the same point as the analog GND. (See section 3 for implications)

4.1.3 Start on Analog Level

A recording may also be started by an analog signal being outside a programmed level or "window".

Levels may be programmed so that a recording will be started when a signal either goes above a set level or under another set level.

If these two levels are set to -2V and +3V respectively, the recording will not start as long as the signal is inside this range. A signal below -2V or above 3V will start the recording.

4.1.4 Digital and Level Start combined

Both the digital and level methods may be used in one recording. The logger will first monitor the digital input for a trig condition. When it occurs it will monitor analog inputs for levels outside set levels. When trig levels are detected the recording starts.

In other words : both trig conditions must be met before recording starts.

4.2 Stop Trig

There are four ways of stopping a recording:

- 1 - A key-stroke or
- 2 - A logical low at the trig input or
- 3 - An analog signal outside a programmed level or
- 4 - Memory full

4.2.1 Stop on key-stroke

Any key-stroke will **always** stop a recording.

4.2.2 Stop on Digital Signal

Recording parameters can be programmed so that a recording will stop as soon as the digital input detects a "low". A "low" is a voltage below 0.8V!. An "open" digital input is held low by an internal resistor.

4.2.3 Stop on Analog Level

Recordings may be programmed to stop on a signal outside a programmed level.

An example may be in place:

A voltage being monitored should vary between 4V and 8V. Any value below 4V or above 8V indicates a malfunctioning. The recording should stop after such an event so that data can be transferred to computer for analysis.

"Stop on level trigs" must then be programmed to 4V and 8V as the lower and upper levels.

4.2.4 Stop when Memory Full.

Recording will automatically stop when the memory is full.

Unless of course endless or circulating memory is programmed, in which case the memory will "wrap around" and only stop on key stroke or stop trig.

4.3 Trig Window - Pre/Post Trig Recording

The PC-Logger 3150 is often used as a trouble-shooter to catch transient events. The area of interest is often the time just prior to the fault condition and then a certain amount after.

The fault condition would trigger the stop.

The time before (pre) and after (post) this event constitute the "Trig Window".

Windows are programmed as a parameter in the "/RECORD/PARAMETERS/" section of the "PC-Logger 3100 PC soft". It requires "circulating" memory which is consequently automatically switched on.

The window is programmed as a pre-trig time and a total time. The post-trig time will of course be the difference between the total and pre-trig time.

The recording, started with the trig-window active, will first go through a "pre-amble", corresponding to the **pre**-trig period, when it is insensitive to stop trigs. After the pre trig period it will register a stop-trig when it occurs and then continue for the **post**-trig period before stopping.

The recording can be left to run for very long periods thanks to the "circulating" or endless memory. The window with correct time will just "slide along" and always be there for transferral after the stop-trig and post trig period.

The entire recording can, of course, be transferred to computer. It is, however, usually more practical to just transfer the window. The software will give you the choice!

When the transferred "window" is presented as graphs, a vertical line indicating where the stop-trig occurred, is shown on the computer screen.

4.4 Illustration: Start, Stop and Trig Sequences

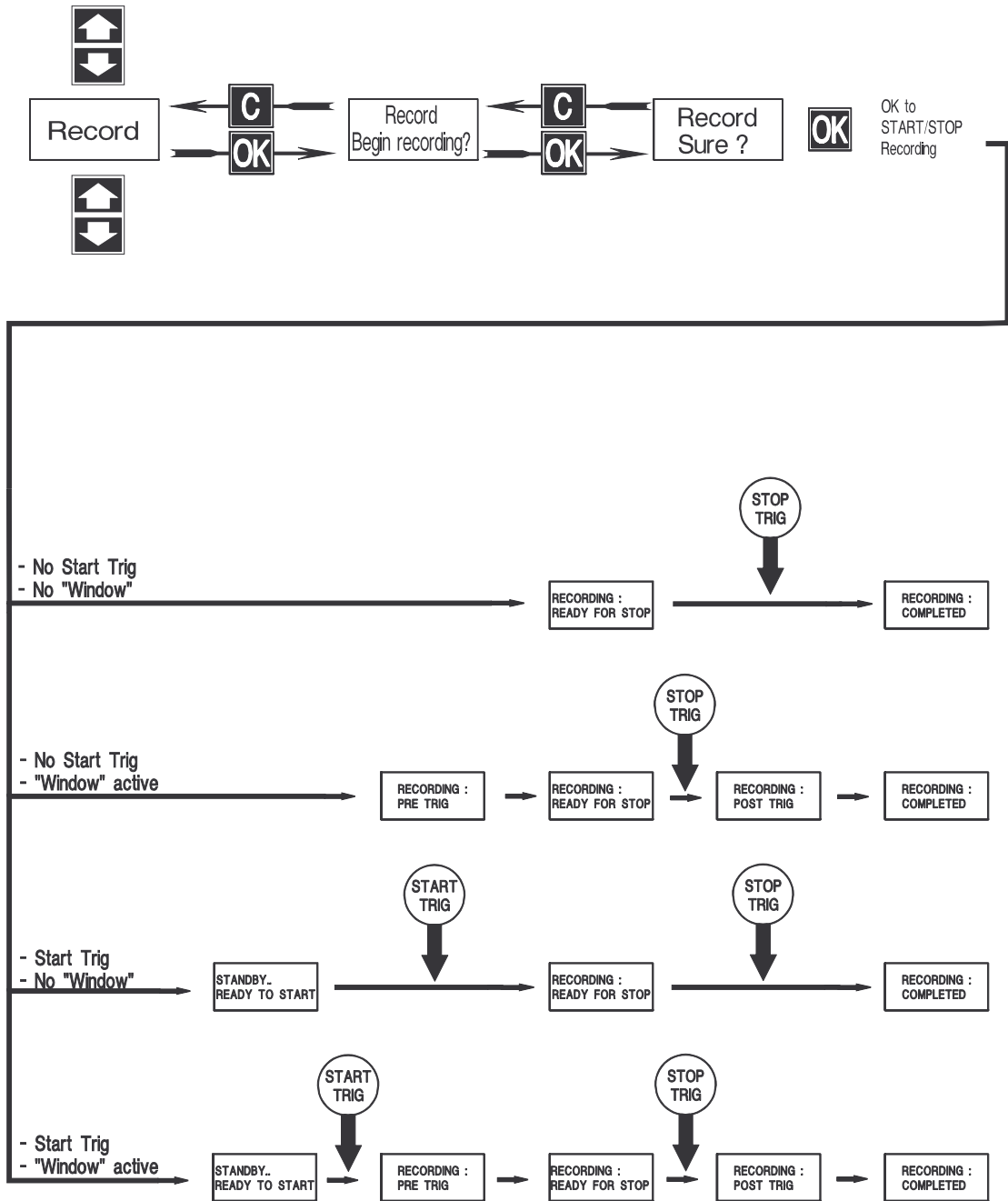

4.5 Trig Output

Several "F" loggers can be "synchronised" by interconnecting them via the trig output.

The trig output goes high reflecting start trig status. It will go low to indicate that a stop trig condition has occurred.

By connecting this output to the digital trig input of another "F" and using these properties it is possible to start the recording of two loggers simultaneously.

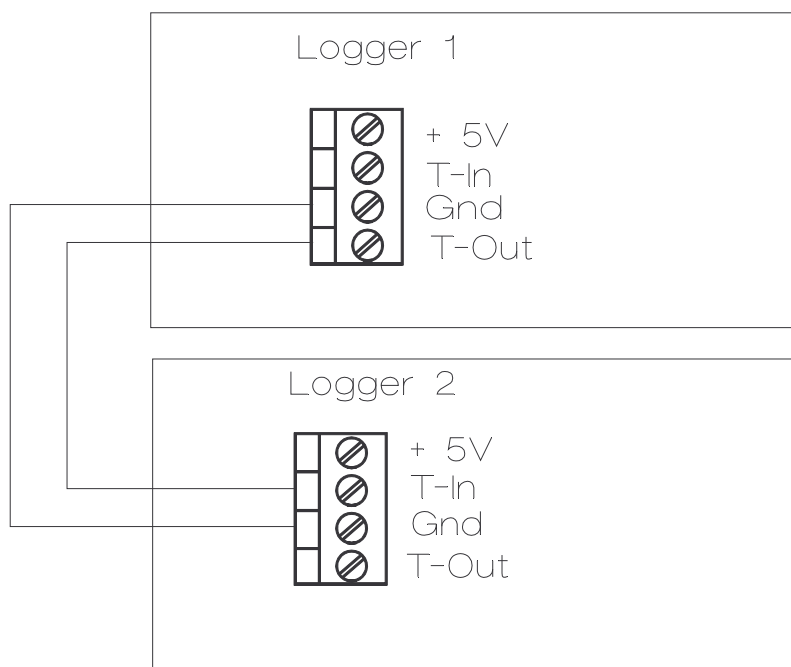

Logger 1 will trig Logger 2 as soon as it starts (or stops) storing values. Logger 2 has to be programmed to start and/or stop on a trig from the digital trig input.

5 MISCELLANEOUS

As is implied by the topic, this section is intended for information that is not readily covered by the other sections of this manual. The information is, however, considered important or interesting enough to be included.

5.1 Master Reset

A master reset of the PC-Logger 3150 can be performed by temporarily shorting pins 7 and 8 of the 15 pin D-Sub connector. A master reset will erase the internal program of the PC-Logger 3150. You will then have to re-boot the program from your computer. Make sure that you have the correct version of the PC-Logger 3150 program installed (the name of the bootable file is BFA_???.LDM), where ??? is a version number.

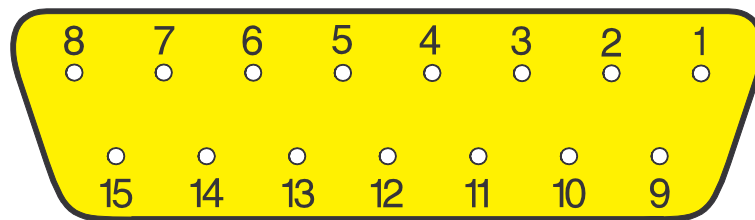

Front view of the D-Sub PC-connector

5.2 Control Program

The program that controls the PC-Logger 3150 is stored in Random Access Memories in the PC-Logger 3150 itself. This makes it possible to modify the way the PC-Logger 3150 operates by simply downloading (or booting) a new program.

Those users who write their own computer programs to operate the PC-Logger 3150, are recommended to study the separate "command manual" and the BOOT command.

6 TECHNICAL SPECIFICATIONS

6.1 ANALOG CIRCUITS

Measuring method :	Successive approximation 11 bits + sign	
Measurement interval :	Off-line :	Min 1 ms per channel. Max 1000ms
	On-line :	Min NA Max 1000ms
Inputs :	8 differential inputs	
	Impedance:	min 400k Ω betw. + and - min 5M Ω betw. + and GND and betw. - and GND Current inputs are shunted by 51 Ω
	Max overvoltage :	30V
	Max overcurrent :	
	(20mA range)	80mA
Ranges : (Factory set or programmable)	Voltages :	+/- 50mV +/- 100mV +/- 1000mV +/- 10V
	Current :	+/- 20mA
Dynamic range : (No of divisions)	Min. +/- 1800 divs. on all ranges	
Resultant resolution :	50mV range	+/-30 μ V
	100mV range	+/-55 μ V
	1000mV range	+/-0.55mV
	10V range	+/-5.5mV
	20mA range	+/-11 μ A
Uncertainty : @ 25°C (all ranges)	0.25% of FSR	
	Tempco : 100ppm + offset drift	

Offset: (@ 25°C)	Initial :	+/-½ division (=bit)
	Drift :	
	50mV range	72ppm/°C
	100mV range	36ppm/°C
	1000mV range	3.6ppm/°C
	10V range	0.4ppm/°C
	20mA range	3.6ppm/°C
Common mode range		
at the:	50mV range	+/-10V
	100mV range	+/-10V
	1000mV range	+/-10V
	10V range	+/-5V
	20mA range	+/-10V
CMRR (DC)	all ranges	min. 80dB

6.2 Auxiliary voltage source

Voltage :	2 - 10V adjustable Max 100mA using supplied PSU
Current :	Max 200mA using PSU with higher power rating

6.3 Trigger input/output

Trigger input	HC-CMOS Schmitt trigger input with 100kΩ series resistor and 100kΩ pulldown.	
Trigger output	HC-CMOS output.	Low < 0.1V (Io > -4mA) High > 4.7V (Io < +4mA)

6.4 Storage memory (optional)

Sizes : 0k bytes (only on-line usage)
64k bytes
544k bytes
1046k bytes

Every stored measurement value occupies two bytes.

6.5 Computer communication

Data is transferred in a serial form to and from the computer. The serial standard conforms to a subset of RS-232.

Format : 8 bit ASCII
1 start bit
8 data bits
1 stop bit
19200 baud

Signals : Tx (2)
(pin no.) Rx (3)
CTS (5)
DTR (6)
GND (7)

Handshaking : Hardware handshaking is employed.
DTR : Signals that the logger is operational (output)
CTS : Signal allowing the logger to transmit (input)

6.6 Commands

See separate manual: "Command manual".

6.7 Power

Voltage 13 - 16 VDC
Operating current Max 500 mA

6.8 Mechanical specifications

(Example)

Width : 165 mm
Length : 315 mm
Height : 50 mm
Weight : 1.7 Kg

OPTION: Digital I/O and Pulse Counters

1 OVERVIEW

The PC-Logger 3150 can, in addition to the analog inputs, be fitted with a digital I/O-interface.

This digital board is mainly used in event-counting applications but can also be used where status or on/off signals must be detected.

The relay outputs of the PC-Logger 3150 are not supported by existing software.

This card is available in two versions: with or without counters.

A fully equipped card has the following I/O's:

- 4 digital outputs (relays)
- 8 digital inputs, 6 of which can be used as inputs to the counters.

1.1 Digital Outputs

Four digital outputs in the form of (relay) contact closures are available. They find their use as alarms and in simple regulating functions and, in the case of the "f", are as such not supported by the software.

The relay coils are, to prolong battery life, powered directly by the mains adapter and not by the internal batteries.

1.2 Digital Inputs

Eight digital inputs are available. Input status of these can be monitored by the computer.

This way you can measure analog signals and at the same time make sure that digital (on/off) control signals assume the correct level at the right time.

Six event counters can be paralleled with these inputs.

By connecting pulse type transducers (flowmeters are often of this type) to these inputs you will get values that represent pulses/time interval. This is the easily transformed into litres per second.

The PC-Logger 3150 software can be said to be treating these values as if they were ordinary analog values or voltages.

The digital inputs are on request fitted with filters for electrically noisy environments.

1.2.1 Opto isolated inputs

The Opto isolated inputs (DI1 - DI8) are used to detect high-level (>10V) signals or where isolation is essential.

The a and b inputs are equivalent and insensitive to reversal of polarity.

The auxiliary output (VO) will power the opto-couplers if no external source is available (see 3.2.1). This output is connected directly to the mains adaptor and is **unfused**. Make sure you have connected it if you want to use this output. Remember also that you lose isolation when you use VO.

1.2.2 TTL-compatible inputs.

TTL- or low-level signals are connected to the so called pulse inputs (P1-P6). These are paralleled with the corresponding DO inputs and do not provide any isolation to the measured/monitored object.

The auxiliary power output for these inputs is V_p .

This voltage is derived from the internal battery through a current limiting resistor

2 COUNTERS

The digital I/O card can be fitted with six sixteen bit counters. Each of these counts up to 65535 and then wraps around to zero. They can be read with constant time intervals resulting in measurements values representing pulses per delta-t.

Flowmeters output a set number of pulses per given unit of volume. They are therefore an excellent example of how the counters can be used to measure flow.

2.1 Reset mode

Reset mode will reset (or zero) the counters as soon as their value is taken care of. This value is then treated as if it were an ordinary analog measurement. (Litres per second maybe ?)

2.2 Normal mode

Normal (or accumulating) mode does not reset the counters when they have been read. Values that are taken with this mode are in fact the time-integral of the transducer output.

This mode is not supported by the software. See the command manual for further information on this mode.

3 CONNECTIONS

Connections are made to the screw terminals under the lid of the PC-Logger 3150. Note that VO is **unfused** and should not be loaded more than the mains adaptor is able to supply and never more than 500mA.

Terminal configuration is shown in the illustration below.

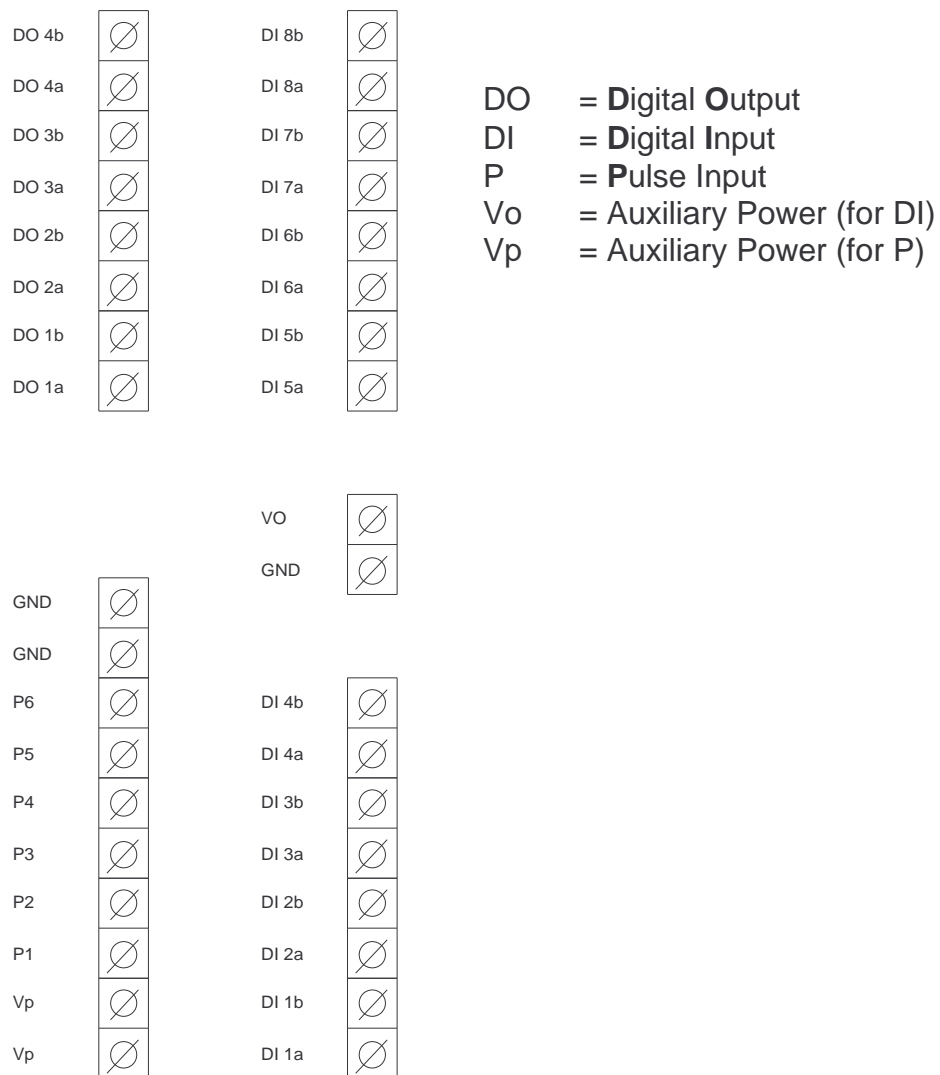

3.1 Digital outputs

The digital outputs are in the form of four normally open relays. These potential free contacts are accessible on DO1a,b - DO4a,b; see figure.

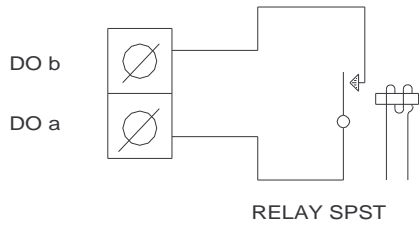

Switching Capability:
Power - 30W/50VA
Voltage - 125V AC/150V DC
Current - 1.25A AC/DC

3.2 Digital inputs

The figure below shows how the TTL and opto-isolated inputs are interconnected.

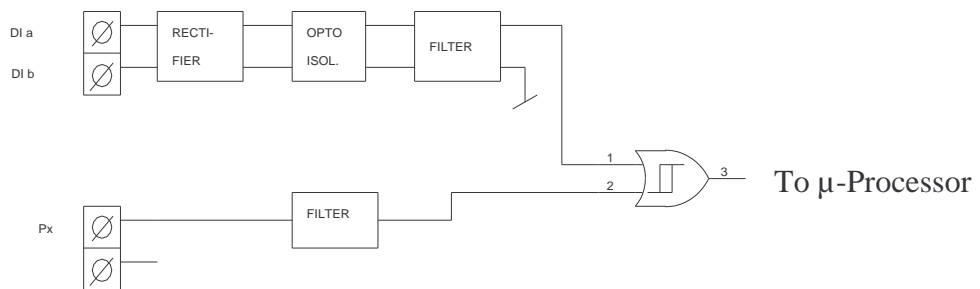

3.2.1 Opto Isolated

The opto-isolated digital inputs can be used in two ways. Which method you use depends on your particular application.

See figure!

The transducer marked "PULSE" has to be able to drive the input: see 4.2.1 for levels and frequencies.

Remember that mechanical contacts always bounce when brought together. This bouncing will, unless filtered, result in a burst rather than one pulse.

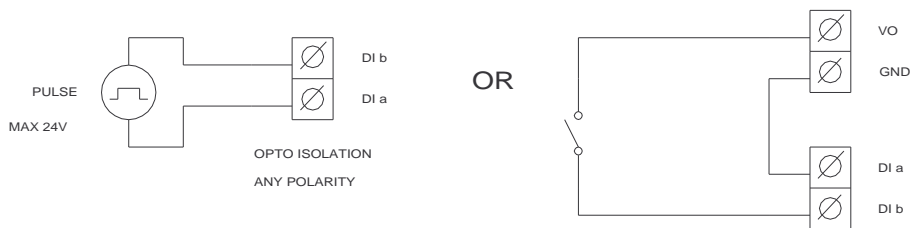

3.2.2 TTL Compatible

The TTL-compatible inputs (P = Pulse in) are connected as in the figure.

Note that signal ground (GND) of the digital card has to be connected to signal ground of the system or transducer that is used with these inputs.

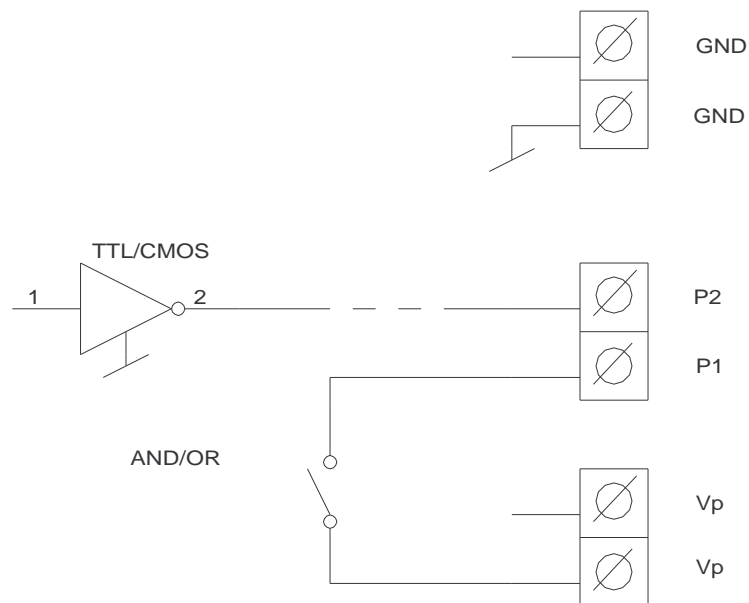

4 TECHNICAL DATA

4.1 Digital Outputs

No of outputs	: 4
Type	: Potential-free relay contacts (NO, SPST)
Switching capability	Power : 30W/50VA
	Voltage : 125VAC/150VDC
	Current : 125VAC/150VDC
	Max operating current : 1A @ 60°C

4.2 Digital Inputs (@ 25C +/-10C)

4.2.1 Opto Isolated Inputs

No of inputs	: 8
"Low" level	: Max 4V
"High" level	: Min 8V
Max input voltage	: 30V
Impedance	: Min 1k Ohms
Input current	: Max 30mA at 30V in
Max frequency	: Min 30kHz at duty cycle 50%

4.2.2 TTL-compatible inputs

No of inputs	: 6
"Low" level	: Max 1.5V
"High" level	: Min 3.5V
Max input voltage	: 20V
Impedance	: Min 50k Ohms
Input current	: Max 30mA at 30V in
Max frequency	: Min 70kHz at 5V and duty cycle=50%
	: Min 30kHz at 10V and duty cycle=50%
	: Min 20kHz at 15V and duty cycle=50%
Min pulse width	: Max 15 μ s

4.3 Auxiliary Power

4.3.1 for Opto-Couplers

Voltage : mains adaptor output, max 15V.

Current : mains adaptor rating -300mA or max 200mA

4.3.2 for TTL-Inputs

Voltage : 4-6V

Impedance : 1k Ω

INDEX

A

Analog ground, 13
auxiliary voltage, 10

B

batteries, 4
block diagram, 4
BOOT, 26
bridge, 16

C

car battery, 6
channel input, 10
circulating memory, 22
C-key, 6
collect data, 5
common mode, 13
Common mode, 28
counters, 31, 32
CTS, 9
current, 8
current loops, 14

D

data memory, 2, 5
detachable, 10
Diff/ Gnd, 10
Diff/Gnd, 12, 16
difference, 12
Differential, 12
Differential Inputs, 11
digital I/O-interface, 31
digital inputs, 32
DIP-switch, 8

dip-switches, 11
DTR, 9
duration, 2

E

endless, 22
endless memory, 23
event counters, 32
event-counting, 31
excitation voltage, 16
extension box, 11

F

fall asleep, 6
float, 13
floating signal, 16
Floating signal, 17
flowmeters, 32

G

G, 10
Gnd, 10, 12
GND, 9
Ground loops, 17

H

header space, 3

I

impedances, 13
input, 10
Input ranges, 1
internal batteries, 4

J

jack panel, 11

K

keys, 20

L

LCD, 5

lid, 10

load cells, 16

logo, 5

M

mains supply, 6

master reset, 26

memory, 3

Multimeter, 5

O

off-line, 1

Off-line, 2

off-line recordings, 5

Offset, 28

OK-key, 5

On-line, 1, 2

Opto isolated inputs, 32

P

post-trig, 23

Power, 9

power input return, 13

Power supply, 6

powered, 6

Pre/Post Trig, 23

pressure sensors, 16

pre-trig, 23

pulse, 32

Pulse counters, 1

R

range, 8

ratiometric, 14

ratiometric transducers, 16

READY FOR STOP, 20

real-time, 2

re-boot, 26

rechargeable batteries, 6

Record, 5

relay, 31

resolution, 8, 27

RS-232, 2

Rx, 9

S

schematic diagram, 14

screw terminals, 10

serial port, 9

shunt resistor, 10

single ended, 10

speed-limitations, 2

spiral cable, 9

Start, 20

Start on Analog Level, 21

Start on digital input, 21

Start on key-stroke, 20

Start Trig, 20

STARTING RECORDINGS, 20

Stop, 20

Stop on Analog Level, 22

Stop on Digital Signal, 22

Stop on key-stroke, 21

Stop Trig, 21

Stop when Memory Full, 22

storage capacity, 3

strain-relief, 10

Successive approximation, 27

T

T-in, 10

total duration, 3

T-out, 10

transducer connections, 5
transmitter, 18
transmitters, 15
trickle charged, 6
trig output, 25
Trig Window, 23
TTL-compatible inputs, 36
Tx, 9

U

Uncertainty, 28

W

window, 23
Volt/Current, 10
Voltage signals, 16
V-out, 13
V-Out, 10
wrap around, 22

