

Belt Trackers

Your belt back on track

less
spillage,
more
performance



CenTrax belt trackers correct mistracking of conveyor belts, on both the load carrying strand and the return strand.

The design is based on 60 years of experience in optimizing conveyor systems. This expertise lies at the heart of the CenTrax belt tracker. After installation, mistracking of your conveyor belt will be a thing of the past.

CenTrax belt trackers prevent unplanned downtime, reduce spillage and wastage, loss of valuable production time and recurring damage. Even under the most extreme conditions, the belt will always remain on the right track, regardless of the direction of belt travel.

CenTrax has excellent tracking characteristics. The belt tracker - including the swivel bearing, central roller and the two tapered rollers, is as flexible as it is robust, which makes CenTrax suitable for the toughest operating conditions and compatible with almost all belt systems.

Why CenTrax

- reduction in operational costs
- increase in safety
- prevents downtime
- prevents spillage
- prevents damage to belt edges and the conveyor belt structure
- prolongs lifetime of the conveyor belt
- 60 years experience guarantees correct diagnosis and a lasting solution

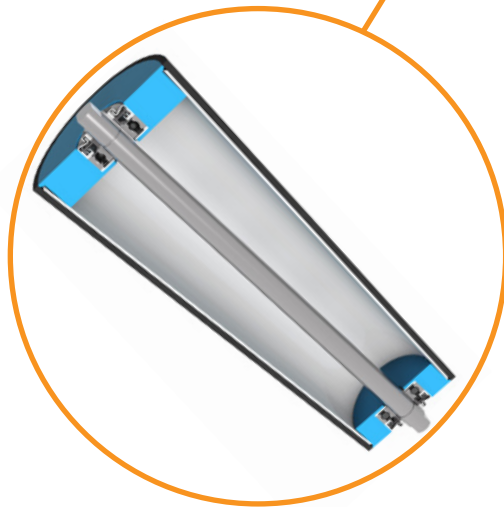
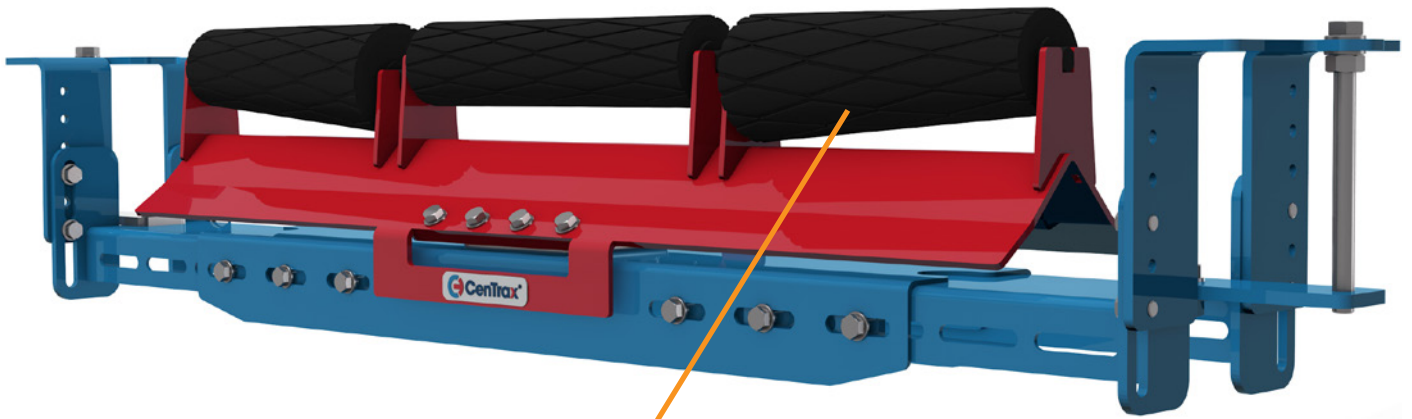

CenTrax uses a minimum of three tracker rollers: one central roller and two tapered tracker rollers. The trough angle of the tapered rollers in the load carrying strand models can be set to any angle from 0° - 47°.

➤ Tracker rollers

Wear resistant

The steel rollers are autoclaved with 8 mm thick, highly wear-resistant rubber. This process is giving a permanent and jointless bond between rubber and steel roller body. Rollers with a polyurethane lining are available for applications where high durability is required.

Explosion Proof

CenTrax is DEKRA certified for use in explosive hazard areas. In this model, the belt tracker rollers are lined with ATEX compliant rubber.

Perfect grip

All rollers have a diamond profile, to guarantee a perfect grip on the belt.

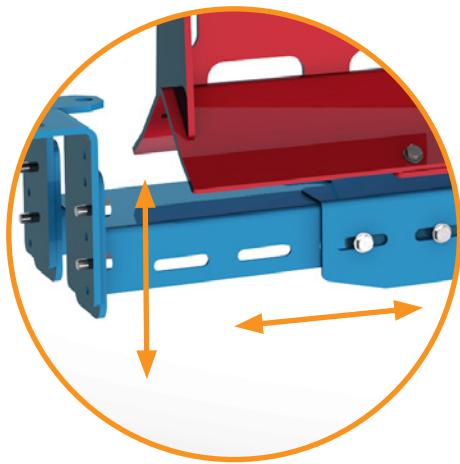

System carrier

- manufactured from high strength steel
- hot-dip galvanised
- variably adjustable in width and height



Maintenance-free

The rollers can be replaced individually but do not require any maintenance once installed.

Special models

In addition to the standard version, customised models are also available. For example, CentTrax belt trackers for belts with a V-shaped return strand, or with 5-part garland roller pairs for the load carrying strand. There is also the option to fit CentTrax to the inner strand. These special versions are available on request. By using as many standard components as possible, delivery times are kept short.

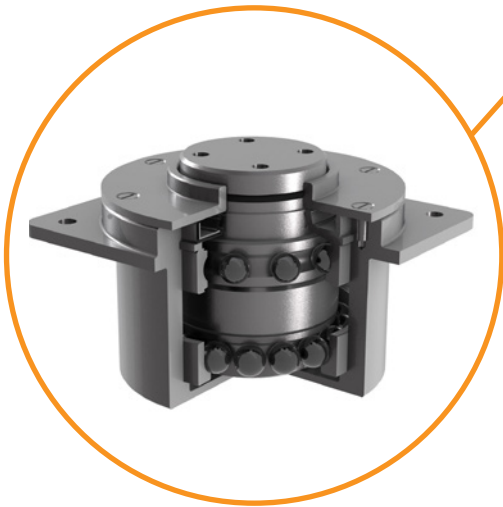
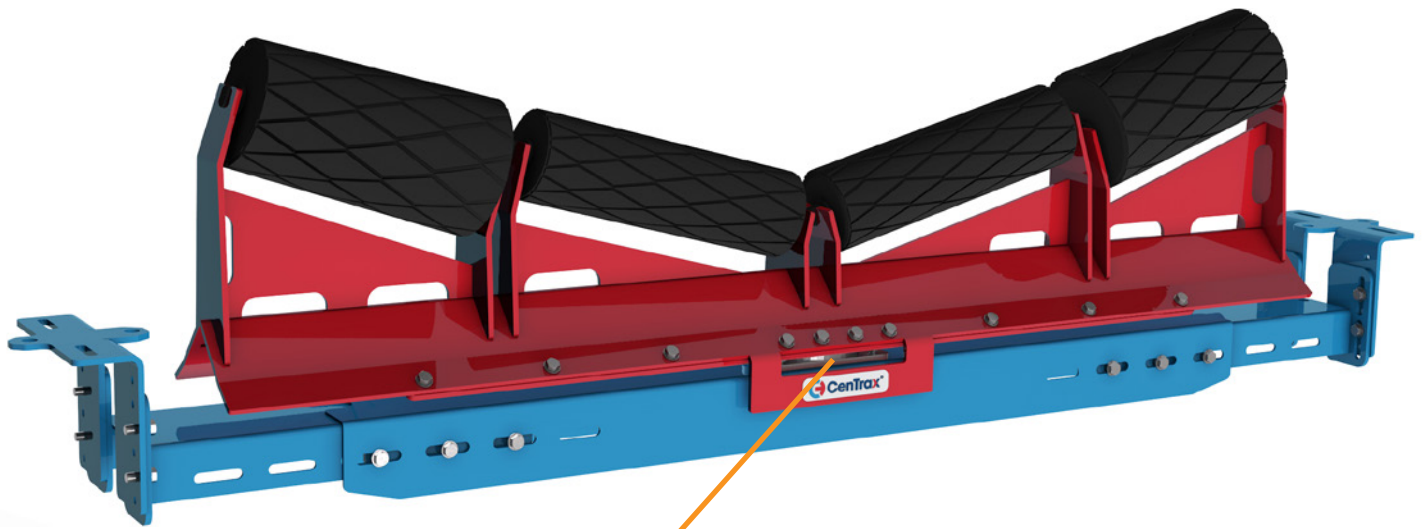

Swivel bearing

- extremely smooth running
- oil-bath lubricated bearings
- resistant to dirt, dust and moisture
- maintenance-free
- extremely long life

Features

- excellent tracking characteristics
- designed to withstand the toughest conditions
- fitted with a unique and fully sealed swivel bearing
- also suitable for reversible conveyor belts
- flexible setup, suitable for virtually any belt construction
- in combination with ATEX rollers, can be used in explosive hazard areas
- (Class I M2 and II 2D, in accordance with EC Directive 2014/34/EU)
- easy installation
- low maintenance
- sustainable
- quick return on investment

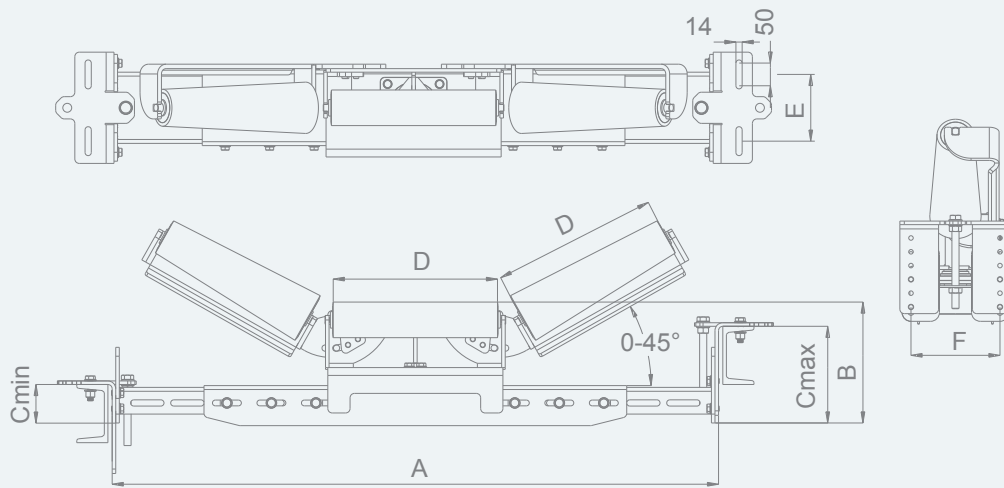

Product dimensions & size table

Type	Belt width	A min.	A max.	B	C min.	C max.	D	Weight (kg)	E	F
SK 650-P (-A/-PU)	650	900	1160	289	104	256	242	63	150	200
SK 800- P (-A/-PU)	800	1050	1316	289	104	256	307	70	150	200
SK 1000- P (-A/-PU)	1000	1250	1516	289	104	256	372	80	150	200
S 1200- P (-A/-PU)	1200	1475	1960	428	152	316	449	156	180	230
S 1400- P (-A/-PU)	1400	1660	2150	428	152	316	514	166	180	230
S 1600- P (-A/-PU)	1600	1870	2360	428	152	316	584	178	180	230
S 1800- P (-A/-PU)	1800	2070	2560	428	152	316	654	188	180	230

Overview of the rollers

Belt width	Type	Central roller	Dimensions	Weight (kg)	Conical roller	Dimensions	Weight (kg)
650 mm	SK 650-P (-A/-PU)	MR65	Ø 80 x 242	3,4	CR65	Ø 83/104 x 242	3,8
800 mm	SK 800- P (-A/-PU)	MR80	Ø 80 x 307	3,7	CR80	Ø 83/110 x 307	4,7
1000 mm	SK 1000- P (-A/-PU)	MR100	Ø 80 x 372	4	CR100	Ø 83/116 x 372	5,4
1200 mm	S 1200- P (-A/-PU)	MR120	Ø 124 x 441	11,4	CR120	Ø 155/196 x 449	18,9
1400 mm	S 1400- P (-A/-PU)	MR 140	Ø 124 x 506	12,7	CR140	Ø 155/201 x 514	20,4
1600 mm	S 1600- P (-A/-PU)	MR160	Ø 124 x 576	14,2	CR160	Ø 155/207 x 584	21,8
1800 mm	S 1800- P (-A/-PU)	MR 180	Ø 124 x 646	15,7	CR180	Ø 155/202 x 654	22,5

P = rollers lined with wear-resistant rubber
 A = rollers lined with ATEX-approved rubber
 PU = rollers lined with polyurethane

Members TBK Group:



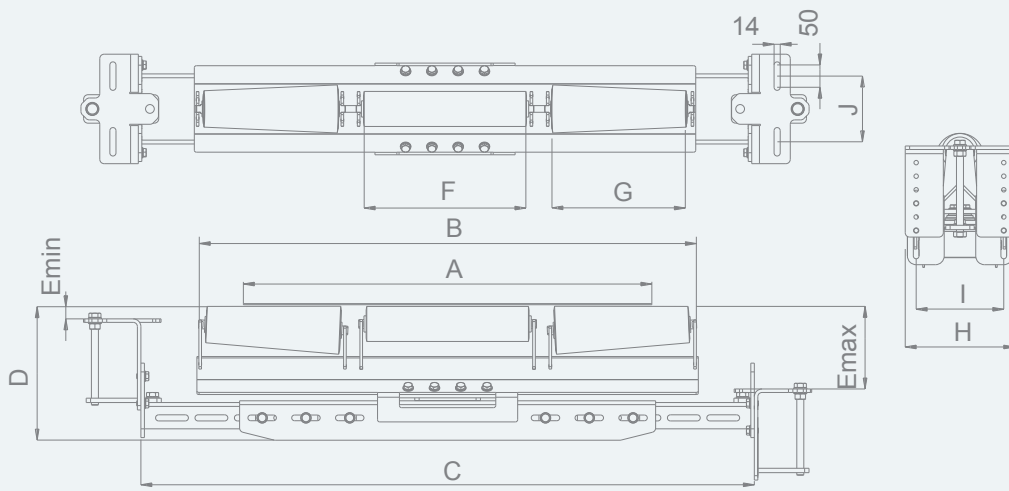

Product dimensions & size table

Type	A	B	C min.	C max.	D	E min.	E max.	F	G	H	I	J	Weight (kg)
SKO-650-P (-A / -PU)	650	750	900	1160	285	20	185	200	242	250	200	150	55
SKO-800-P (-A / -PU)	800	900	1050	1316	285	20	185	307	242	250	200	150	61
SKO-1000-P (-A / -PU)	1000	1100	1250	1516	285	20	185	372	307	250	200	150	67
SO-1200-P (-A / -PU)	1200	1300	1475	1960	400	152	316	441	360	280	230	180	135
SO-1400-P (-A / -PU)	1400	1500	1660	2150	400	152	316	441	450	280	230	180	146
SO-1600-P (-A / -PU)	1600	1700	1870	2360	400	152	316	506	514	280	230	180	156
SO-1800-P (-A / -PU)	1800	1900	2070	2560	400	152	316	576	584	280	230	180	166

Overview of the rollers

Belt width	Type	Central roller	Dimensions	Weight (kg)	Conical roller	Dimensions	Weight (kg)
650 mm	SKO 650-P (-A / -PU)	MR50	Ø 80x190	3,4	CR65	Ø 83/104x242	3,8
800 mm	SKO 800-P (-A / -PU)	MR80	Ø 80x307	3,7	CR65	Ø 83/104x242	3,8
1000 mm	SKO 1000-P (-A / -PU)	MR100	Ø 80x372	4	CR80	Ø 83/110x307	4,7
1200 mm	SO 1200-P (-A / -PU)	MR120	Ø 124x441	11,4	CRO120	Ø 160/193x360	16,4
1400 mm	SO 1400-P (-A / -PU)	MR120	Ø 124x441	11,4	CR120	Ø 155/196x449	18,9
1600 mm	SO 1600-P (-A / -PU)	MR 140	Ø 124x506	12,7	CR140	Ø 155/201x514	20,4
1800 mm	SO 1800-P (-A / -PU)	MR160	Ø 124x576	14,2	CR160	Ø 155/207x584	21,8

P = rollers lined with wear-resistant rubber
 A = rollers lined with ATEX-approved rubber
 PU = rollers lined with polyurethane